

1 2 3 4 5 6 7 8

A

B

C

D

E

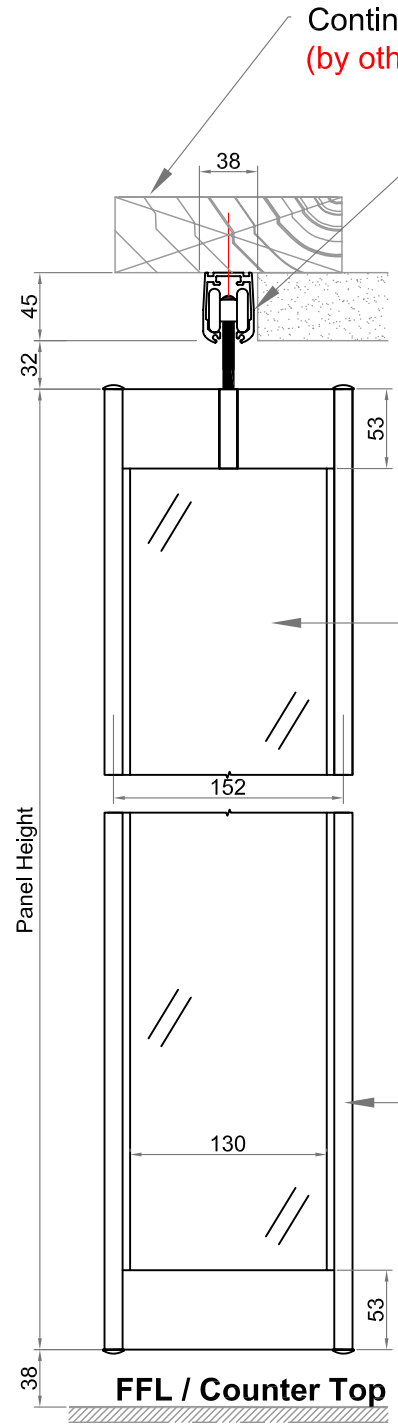

END ELEVATION 1:5

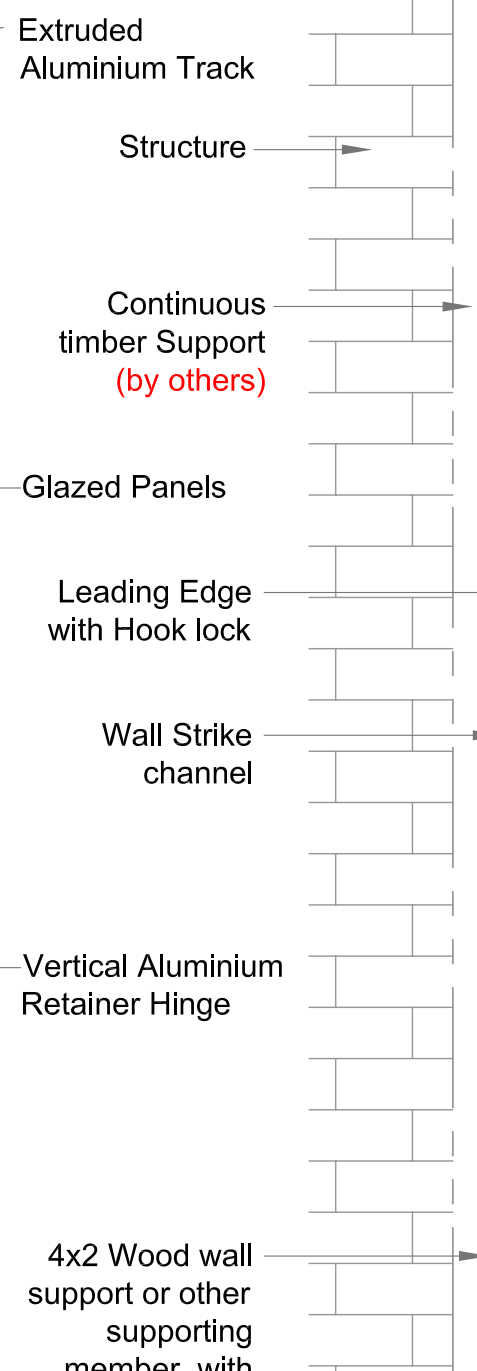

FRONT ELEVATION 1:10

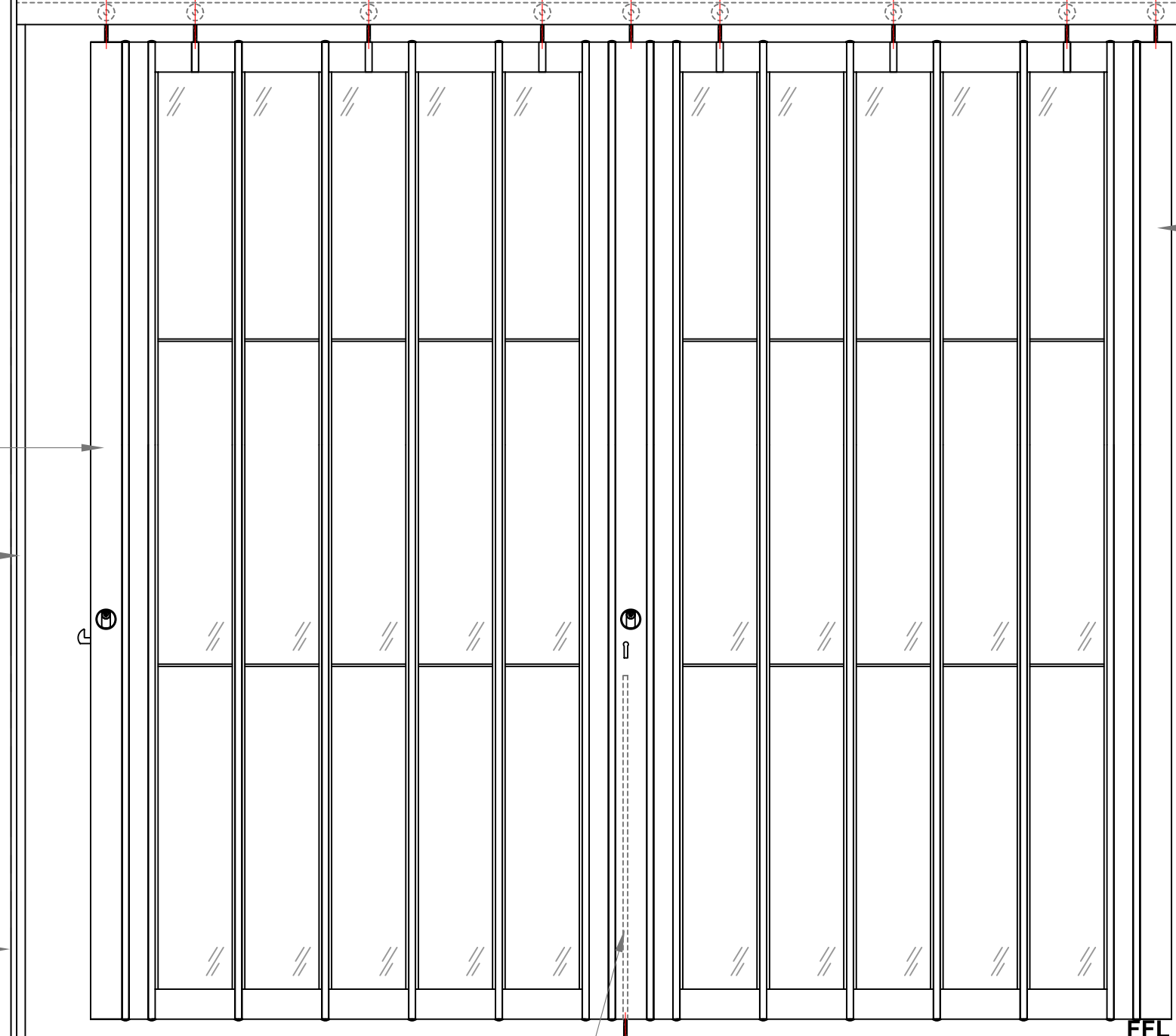

Optional Post with drop lock (as required) for added security

Panels
Clear, shatterproof Lexan or Tempered glass inserts allow unobstructed views while providing solid security and blocking refuse, odor and smoke.

Lexan

- 8mm thick panels
- Max height 4.9m
- 2.25Lbs. Per Sq. Ft.

Glass

- Clear tempered glass panels
- Max height 4.2m
- 2.5Lbs. Per Sq. Ft.

A

B

C

D

E

GUARDIAN
SLIDING GRILLES
Tel: +44(0)1702 512424
Fax: +44(0)1702 260117
www.slidingfoldinggrilles.co.uk

UNLESS OTHERWISE INDICATED ALL DIMENSIONS IN MILLIMETERS

DRAWN	CHK'D	APP'D	DATE	SCALE
CH				
TITLE CLEAR Wave Elevation Sliding Grilles				

Job No:
Guardian maintains a policy of progressive design and we reserve the right to modify specifications without prior notice or alteration to this drawing

ISSUE	DATE	APP'D

1 2 3 4 5 6 7 8

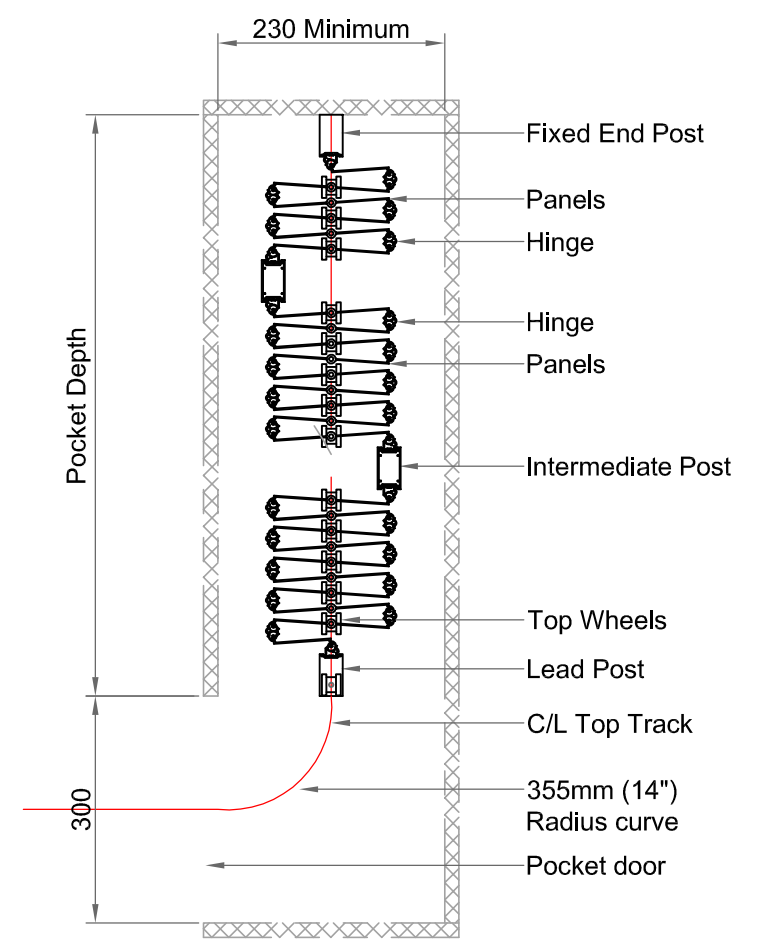
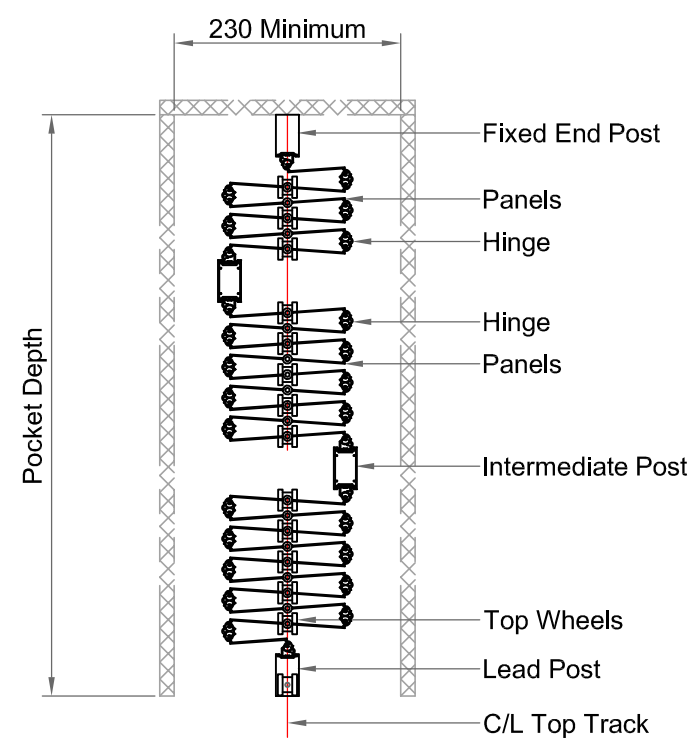
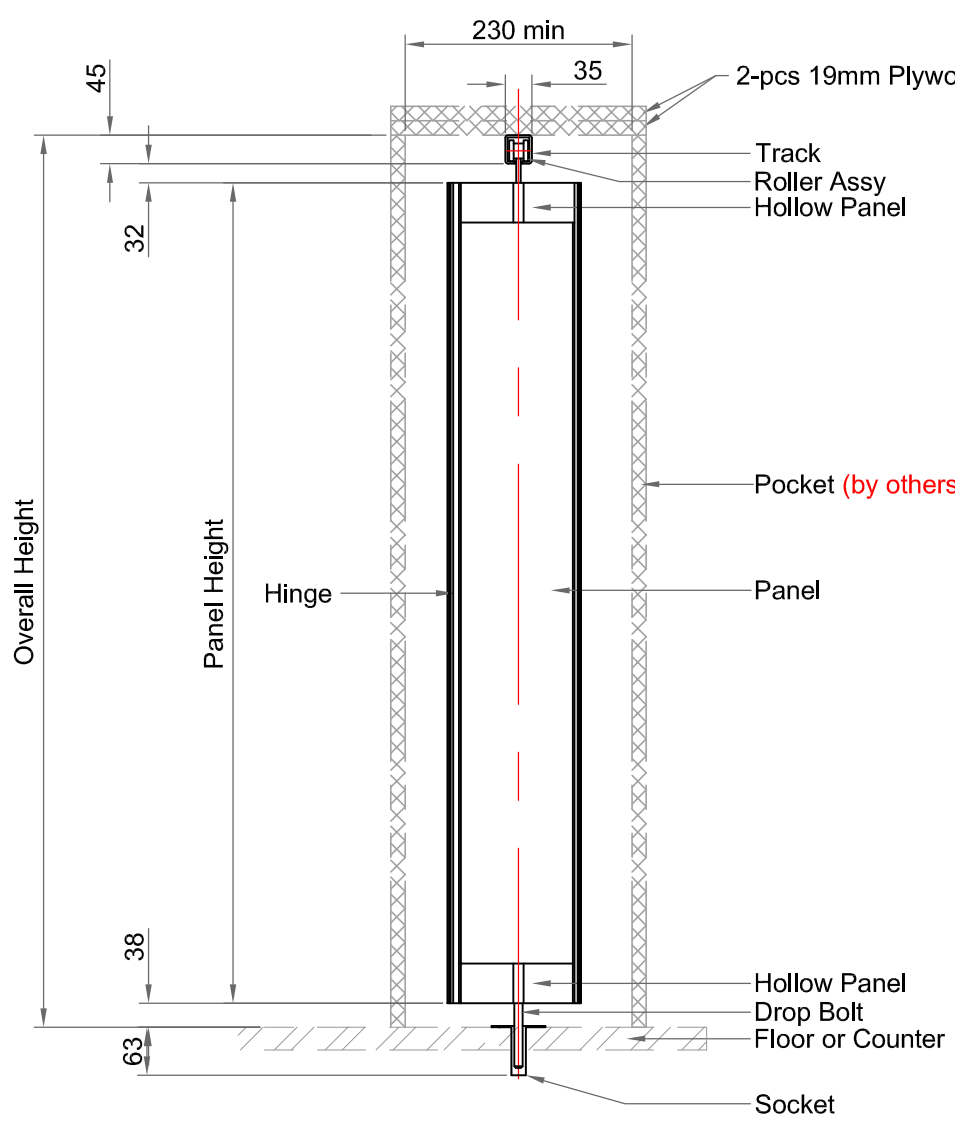

Minimum Stacking
 1.05" per Foot of opening + 3.5" per post, or
 Approximately 2" per Foot of opening

Design Construction Details

- Minimal headroom required - 38mm wide x 46mm high track mounts to overhead structure to support unit.
- No floor track is required.
- Maximum recommended width of a single unit section is 30' 0" (before using a bi-parting unit).
- Maximum intermediate member spacing is 13' for full height units, 7' for countertop units.
- Operation is manual push / pull only.
- Minimum height for all units is 2' 0", Minimum width for all units is 4' 0".
- The grille support should be design to carry the weight of a fully stacked door at any point along its length

Optional Finishes

- For standard clear anodised components:**
- **Color Anodized: medium bronze, dark bronze or champagne**
 - **Custom wet paint**

GUARDIAN
 SLIDING GRILLES
 Tel: +44(0)1702 512424
 Fax: +44(0)1702 260117
 www.slidingfoldinggrilles.co.uk

UNLESS OTHERWISE INDICATED
 ALL DIMENSIONS IN MILLIMETERS

DRAWN	CHK'D	APP'D	DATE	SCALE
CH			21/12 /11	
TITLE Pocket and Sliding Grilles information				

Job No:
 Guardian maintains a policy of progressive design and we reserve the right to modify specifications without prior notice or alteration to this drawing

ISSUE	DATE	APP'D

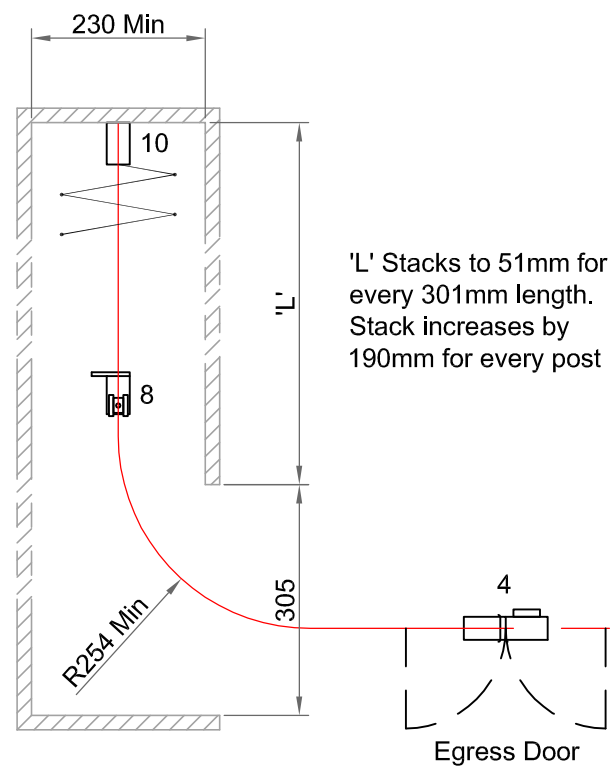

'L' Stacks to 51mm for every 301mm length. Stack increases by 190mm for every post

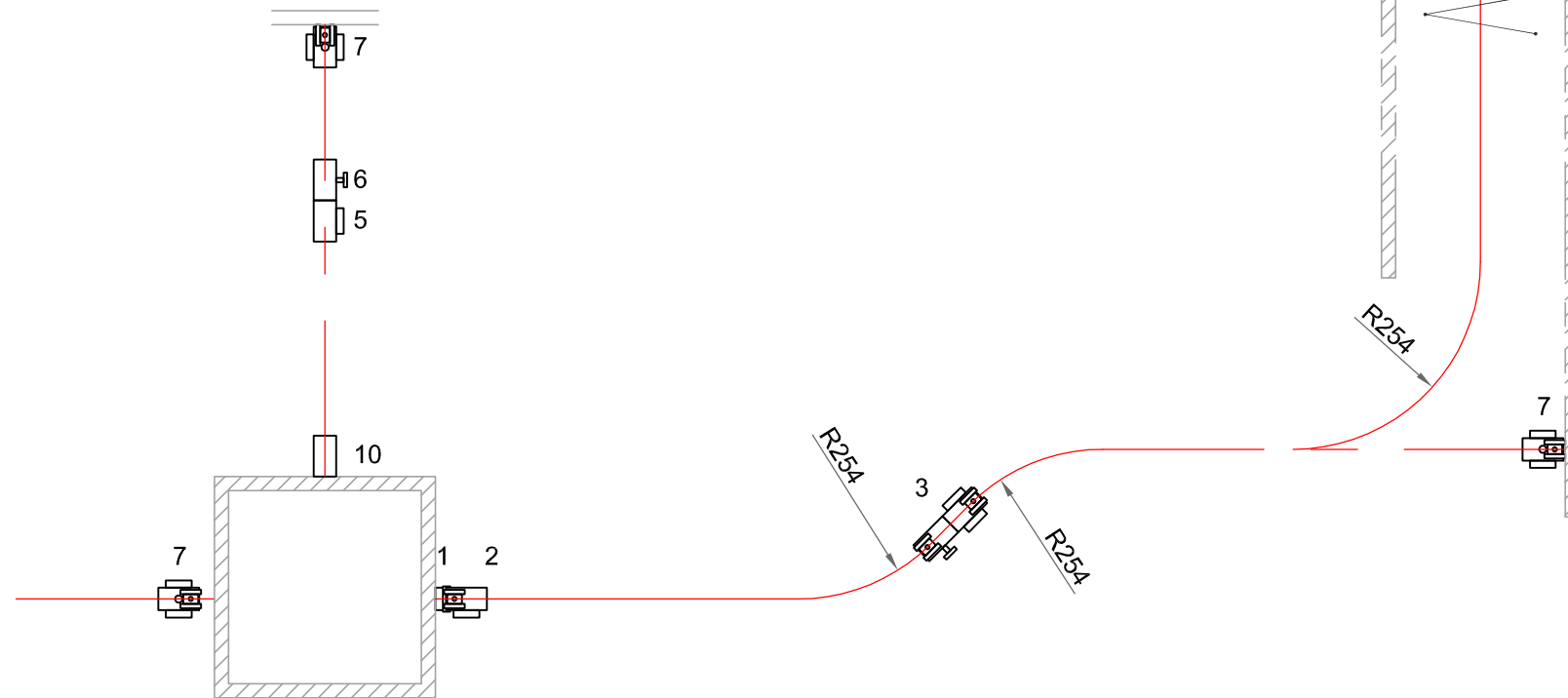

See DWG DD-02 for Post Details



GUARDIAN
SLIDING GRILLES

Tel: +44(0)1702 512424
Fax: +44(0)1702 260117
www.slidingfoldinggrilles.co.uk

UNLESS OTHERWISE INDICATED
ALL DIMENSIONS IN MILLIMETERS

DRAWN	CHK'D	APP'D	DATE	SCALE
-------	-------	-------	------	-------

CH				
----	--	--	--	--

TITLE	Samples of Configuration Sliding Grilles			
-------	--	--	--	--

Job No:

Guardian maintains a policy of progressive design and we reserve the right to modify specifications without prior notice or alteration to this drawing

ISSUE	DATE	APP'D
-------	------	-------

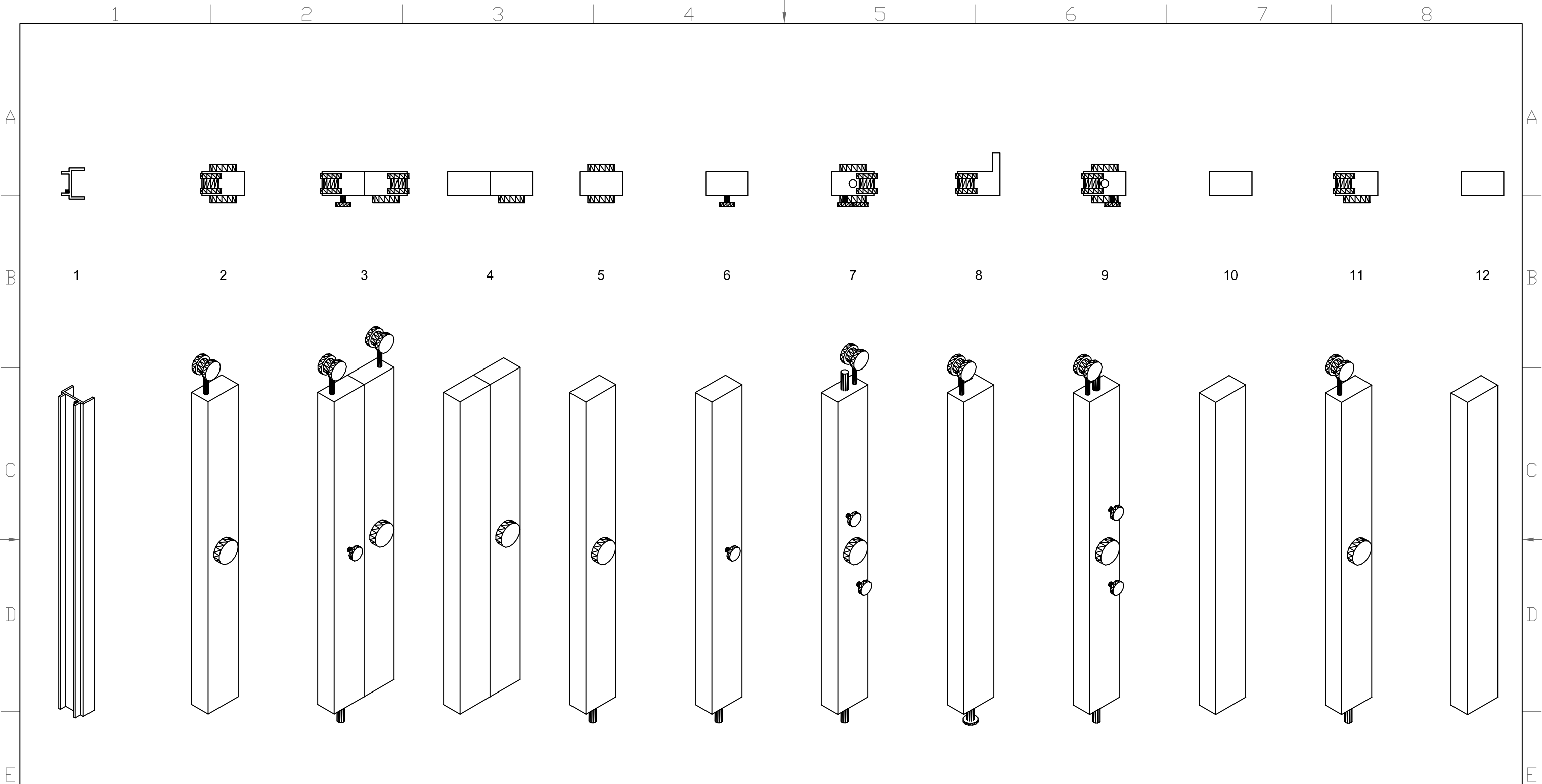

- 1. Wall Jamb
- 2. Lead Post
- 3. Bi-Part c/w Drop Bolt on one Post
- 4. Egress Door
- 5. Intermediate Post c/w Cylinder & Drop Bolt
- 6. Intermediate Post c/w Knob & Drop Bolt
- 7. Top & Bottom Post c/w Drop Bolts
- 8. Trailing Back Post
- 9. Three Way Locking Post c/w Drop Bolts
- 10. Fixed End Post
- 11. End post c/w Drop Bolt, Track Stop & Back Plate
- 12. Connecting Post



UNLESS OTHERWISE INDICATED
ALL DIMENSIONS IN MILLIMETERS

DRAWN	CHK'D	APP'D	DATE	SCALE
CH				

TITLE
**Vertical Posts
Sliding Grilles**

Job No:
Guardian maintains a policy of progressive design and we reserve the right to modify specifications without prior notice or alteration to this drawing

ISSUE	DATE	APP'D